



PHOTOVOLTAIC



PLANT MONITORING

rev. 1.0
06 November 2020

Kernel Sistemi
 Kernel Sistemi s.r.l. , via Vignolese n. 1138
 41126 Modena - ITALY
 Tel. 059 469 978 - Fax 059 468 874
www.kernelgroup.it

INDEX

1 PLANT MONITORING.....3

1.1 Introduction.....3

1.2 Consideration about SMU connection architecture.....5

1.3 RS 485 BUS.....5

1.4 Generic BUS connections layout.....6

1.5 Star connections layout.....7

1.6 RS 485 chain connection layout.....8

1.7 Optic Fiber Single Ring.....9

1.8 Optic Fiber Double Ring.....10

1.9 Optic Fiber Multidrop Architecture.....11

2 CONTACTS.....12

Comparison among different architecture			
RS 485	Fiber Single Ring	Fiber Double Ring	Fiber Multidrop
cheaper	Expensive	More expensive	
RS485 converter NOT needed	One RS485 to fiber converter needed	Two RS485 to fiber converter needed	
One RS485 COM port Data Logger needed	One RS485 COM port Data Logger needed	Two RS485 COM port Data Logger needed	
Not insulated	Complete insulation		
SPD strongly advised	SPD NOT required		
A fault can cause the loss of the entire network or not, depending on the kind of fault	A fault cause the loss of the entire network	A fault does not cause the loss of the network but it is non possible to locate the fault	A fault do not cause the loss of the network and it is possible to locate the fault

1 Plant Monitoring

1.1 Introduction

The purpose of a plant monitoring system is to keep the plant under real-time control, to understand if it is working properly and to get immediate feedback from the field if any issue occurs. A large plant is built of thousands of PV panel connected in series/parallel to form strings and several inverters connected via String Combiner Box (SCB). Usually into an SCB find place a breaker, two bus bars to make the parallel connection of the strings terminal, fuses, and an intelligent card: String Monitor Unit (SMU). The SMU measure the mains parameters of the strings: current, voltage, temperature and may have some other auxiliary inputs and a communication port. The SMU are connected in different ways to the control room of the plant, so a supervisor SCADA system can collect every information about the status of the plant and, eventually, let it available on a cloud system.

In a big plant, with thousands of PV panels spread onto a wide area of thousands of square meters, a monitoring system can help the plant manager to find the exact position of a malfunctioning string of PV panels, establishing an emergency service and avoiding lack of production and loose of money.

In a big plant it is usual to have several inverters located in inverter rooms, each inverter is powered by its group of PV panel and each of them have its own data logger that collects data from the field, all data loggers are connected to the main control room, as shown in the following figure.

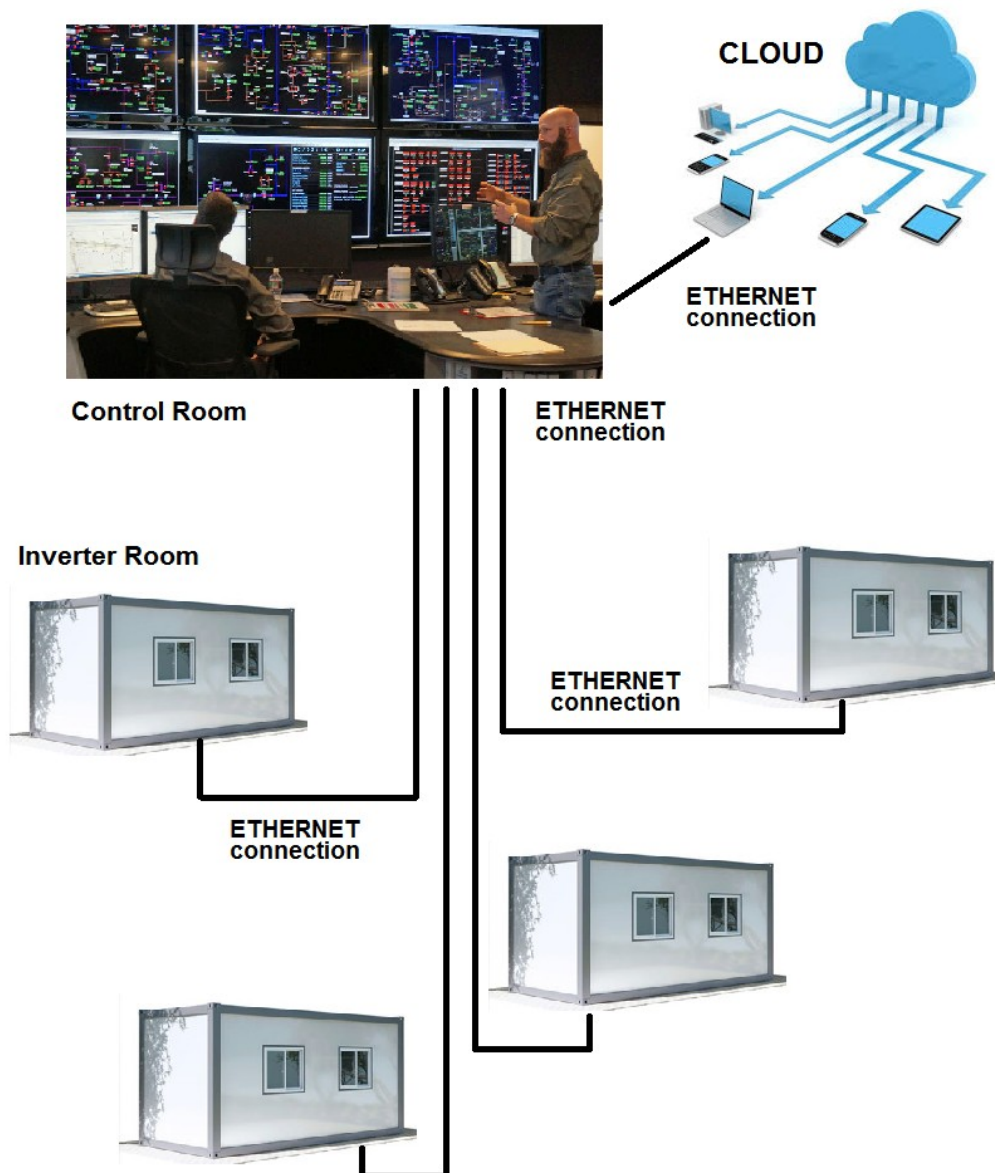

Each inverter room contains one or more inverter connected to PV panels, panels are connected to form a string (a group of 20..40 panels connected in series), to build up the proper voltage level for the inverter. A SMU can monitor the current that flows into the panels string.

Usually a SMU can measure the current of several strings, depending on the number of channels, that can usually range from four to twenty-four. There are mainly two techniques to measure the current: by shunt resistor or by hall effect sensors, every technique has its own advantages and disadvantages, that we will explain later. Moreover, there are different ways to connect the SMU to the inverter room and to the control room: by an RS485 bus, by optical fiber and by wireless radio connection.

The figure below shows the power connection from some groups of string to the inverter: all the plus terminal of the strings are connected together, the minus terminal of each string is connected to an input of a SMU, so the SMU can measure the current of each string. The data connection is not shown, it will be discussed later.

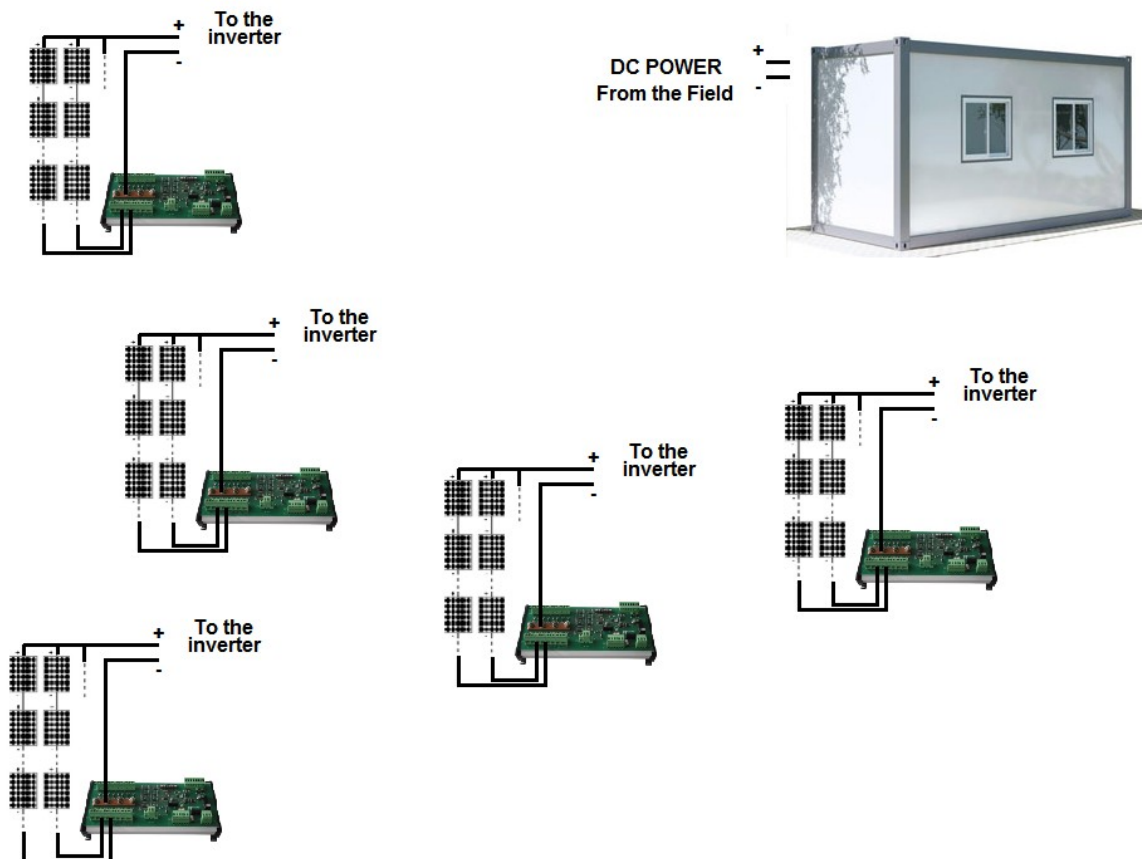

Fig. 2 - Inverter Room and SMU with string connections

For example: a 1 MWatt inverter can be powered by 2222 PV panel of 450 Watts each, supposing to create strings of 30 panels each for a 1000 V system, the total number of string will be 74. Such plant can so be monitored by five sixteen channels SMU: $5 * 16 = 80 (> 74)$.

Usually each inverter room is managed by a data logger or PLC that controls the inverter status and some more automation processes, other the data collecting from the field. The PLC has usually at least two communication ports, one of this is an ETHERNET port connected to the hub of the main control room, the other is a field bus port connected to the SMU.

In the next sections we will discuss about the different kinds of field bus that can be used, both on technical and economical points of view.

1.2 Consideration about SMU connection architecture

In this section we will explain the different technique and field bus used to connect many SMU to the relative Data Logger or Supervisor located into the Inverter Room, without any relation with power lines.

In this architecture the Data Logger acts as a master of the communication network, and each SMU acts as a slave node of the network: the master polls every slave sending a query and waiting for a reply at a specified scan time interval. The query reaches every slave connected at the same time but only one can reply.

Regardless the choose of the filed bus, it is mandatory that in every group of SMU each SMU have a unique Identification Number (node address) so only the indexed SMU is enabled to reply to the query.

1.3 RS 485 BUS

RS485 is a standard hardware layer used to connect electronic devices together in a network: the cable us a twisted pair two wires plus GND with shield. There are many different ways to connect the cables: star, bus or mixed.

In any case, refers to figure below that shows the connector and, to simplify the cabling, keep in mind that in the CN2 connector pins 1-4, 2-5, 3-6 are internally connected so it is possible to put two cables from different directions in the same connector.

Refer to TIA/EIA-485-A for more detail on RS 485 specifications. In PV application high communication speed is usually not required, so the baud rate is typically 19200 or lower to guarantee the best EMC immunity.

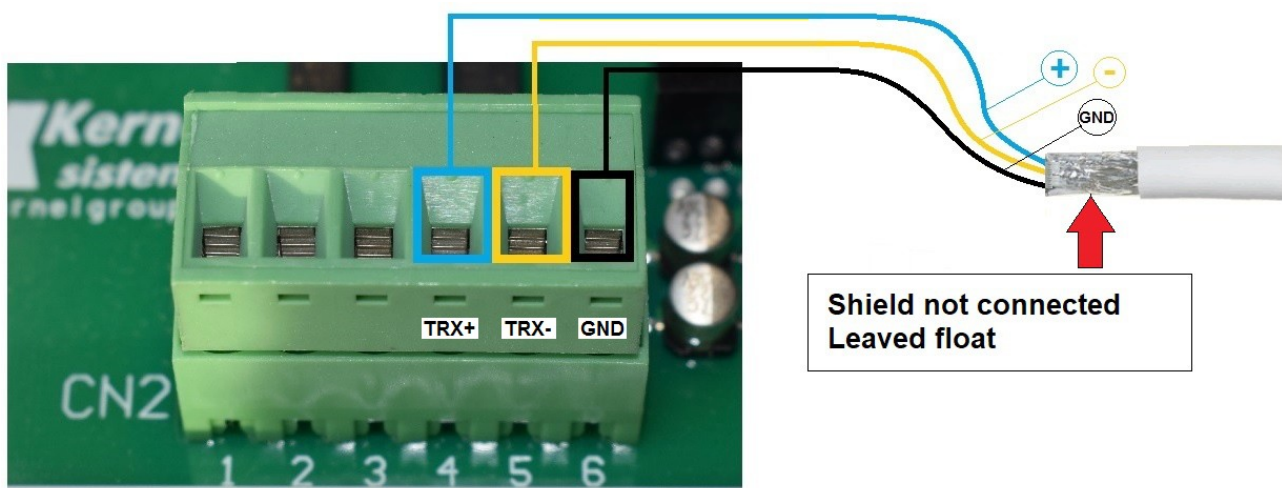

Fig. 3 - RS 485 connector and cable

Lighting and over-voltage can hit and damage RS485 drivers and can propagate among many SMU, so it is important to protect the RS 485 wires with Suppressor Protection Device SPD and it is important to check periodically the SPD specially after a thunderstorm and replace them if necessary.

If a break occur in a RS 485 bus some communication can be lost, it depends on the kind of failure. There are two kind of failure in a RS 485 driver: open circuit or short circuit. In case of open circuit failure only the SMU broken is lost, it seems that the SMU is disconnected or turned off but the others SMU continue to work in a regular way. In case of short circuit on a single SMU the communication with all the SMU connected to the same bus are lost because the electric signal cannot run on a shorted cable, to restore the system it is necessary to locate the broken SMU and replace it. Locating the broken SMU can be made disconnecting one SMU at a time verifying each time if the communication works.

1.4 Generic BUS connections layout

In the figure below we show a generic bus layout: all SMU are connected with a cable with no specified rule. All the TRX+ are connected together, so well as all the TRX- and GND. There is no specific rule to assign the node address, on the logic point of view there is no difference among the nodes, but is important that each node is unique.

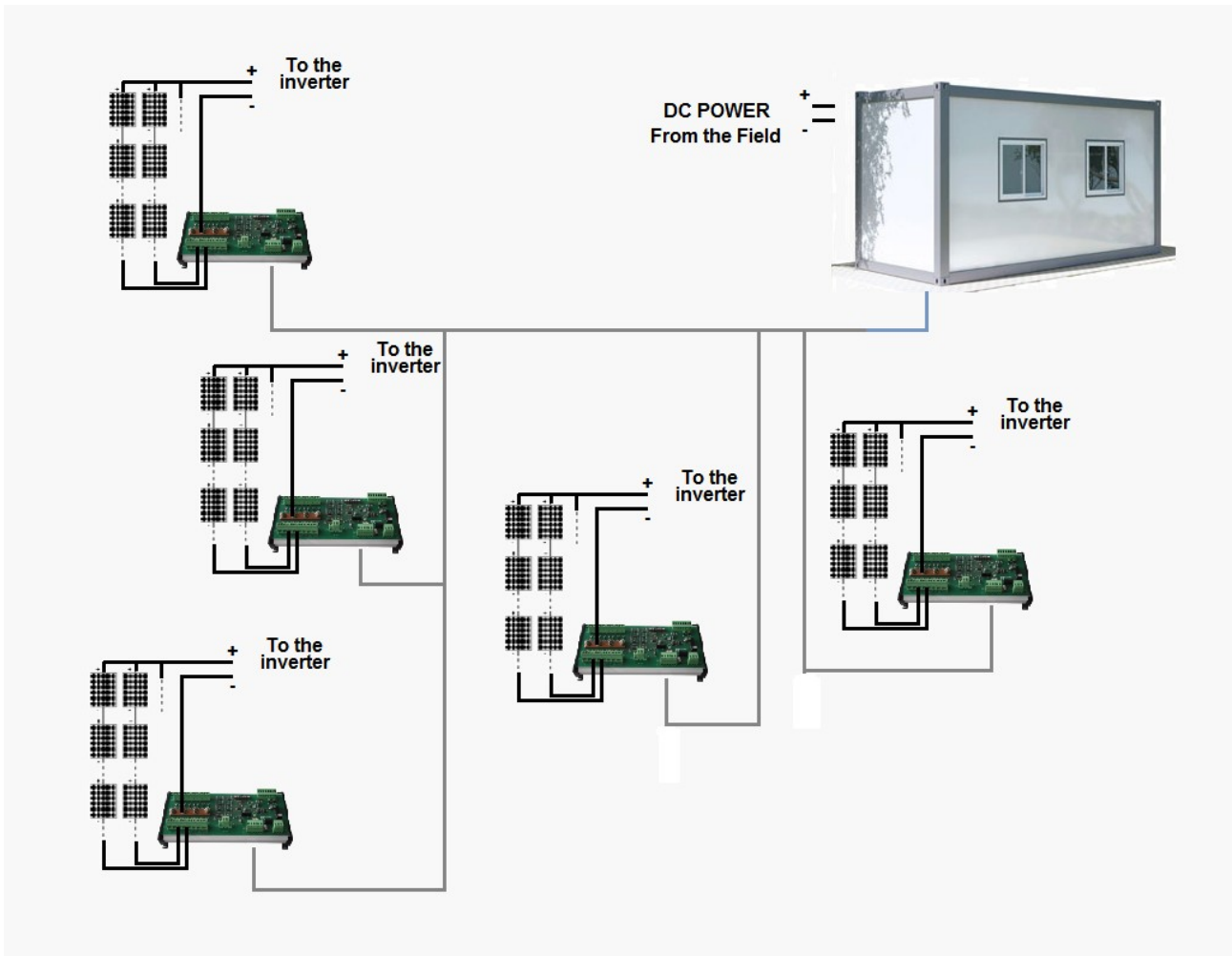

Fig. 4 - Generic BUS connections layout

1.5 Star connections layout

In the figure below we show a star bus layout: all the SMU are connected with a single cable to the same connection point. This layout is possible but not advised, it requires a longer total cable length: longer is the distance, greater is the exposure to electromagnetic disturbances

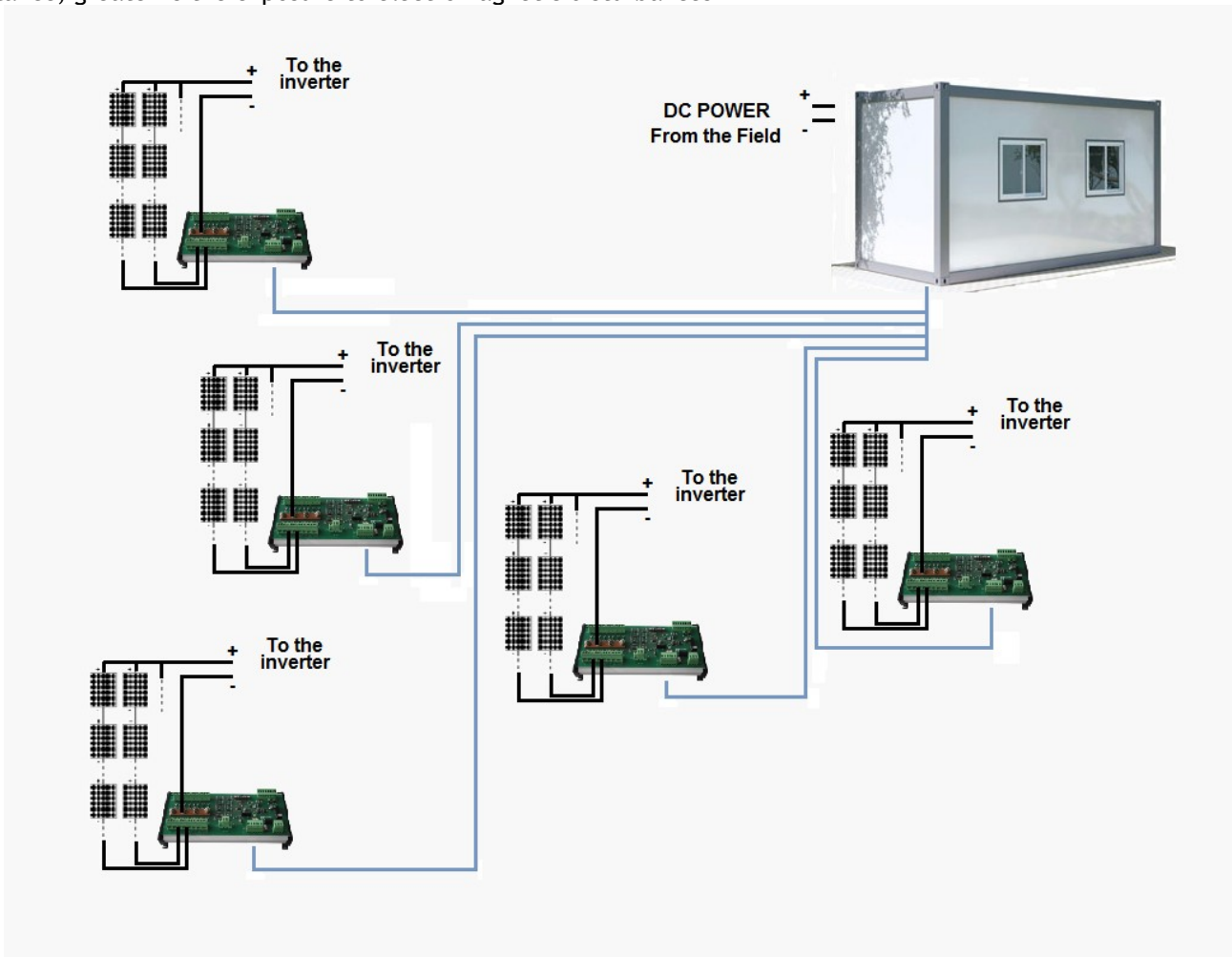

Fig. 5 - Star connections layout

1.6 RS 485 chain connection layout

In the figure below we show a chain connection layout: the RS485 cable starts from the inverter room, reaches the first SMU, than continue towards the second and so on until reaches the last. This is the most common used and advised configuration. Also in this case the node addresses can be assigned without specific rule, but the most logical way is to assign progressive numbers from 1 to the last

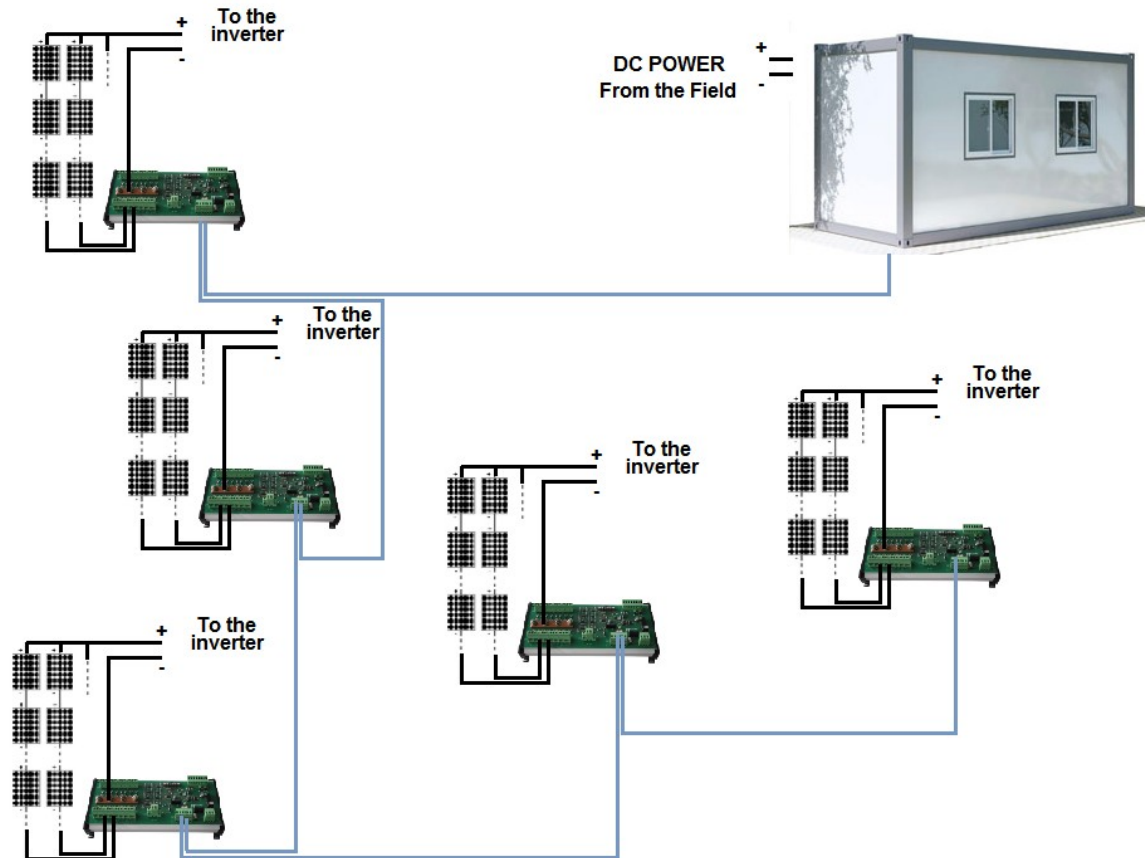

Fig. 6 - RS 485 chain connection layout

1.7 Optic Fiber Single Ring

To improve noise immunity and to have a complete electrical insulation among the SMU it is advised to replace the copper wires with a optic fiber. There are three possible way to connect SMU with Optic Fiber: Single Ring, Double Ring and multidrop.

In a RS485 connection the transmission is half duplex bidirectional, instead in an optic fiber the transmission is unidirectional from Transmitter to Receiver.

In a single ring architecture the Data Logger is connected to a RS485 to optic fiber converter that has two terminal: TX and RX. Each SMU has a single TX transmitter and a single RX receiver: the TX terminal of the converter is wired to the RX terminal of the first SMU, the TX terminal of the first SMU is wired to the RX terminal of the second SMU and so on until the TX terminal of the last SMU is wired to the RX terminal of the converter. In this way all the SMU are connected in a ring, the query from the Data Logger is transmitted to the first SMU and forwarded to the others until reaches the converter. The indexed SMU whose address matches the query address attaches the answer that reaches the converter passing through the remaining SMU. If a break of any wire occur along the ring all communications are lost because the query or the answer cannot complete the loop.

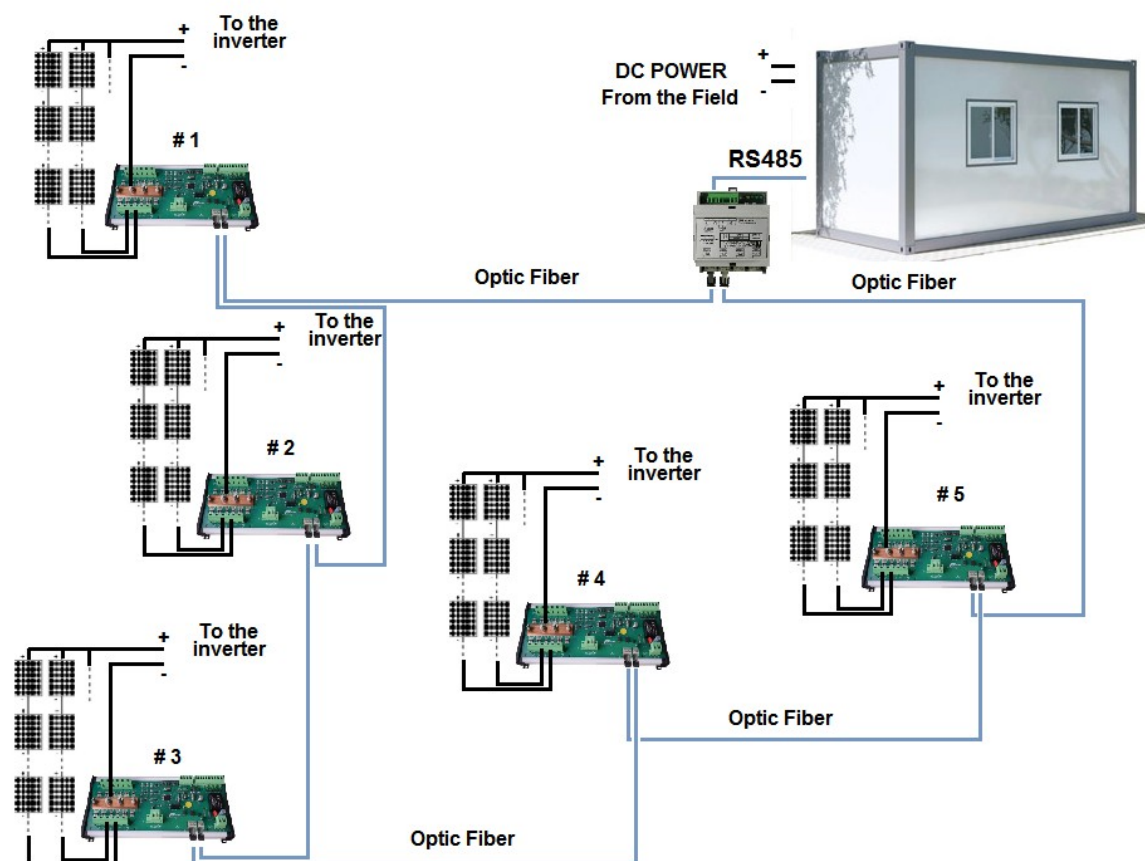

Fig. 7 - Optic Fiber single ring

To avoid the lost of a complete network for a single failure it is possible to use a redundant architecture like double ring or multidrop.

1.8 Optic Fiber Double Ring

In a double ring architecture the redundancy is assured if the Data Logger has two independent COM port to drive two independent optic fiber ring. Each COM port is connected to a different RS485 to fiber converter that drives a SMU ring. Each SMU has two independent COM port that drives its own TX transmitter and RX receiver, so there are two TX and two RX terminals per each SMU.

In this way there are two independent rings: usually the Data Logger uses only one of them, but if a failure occurs on the main ring can immediately switch to the other, keeping the communication active until the fault is repaired. With this architecture it is not possible to find which SMU or which section of cabling is broken, but only to guarantee the redundancy of the system and the continuity of service.

During the normal use the alternate ring has to be periodically checked to be sure that it will work in case of necessity.

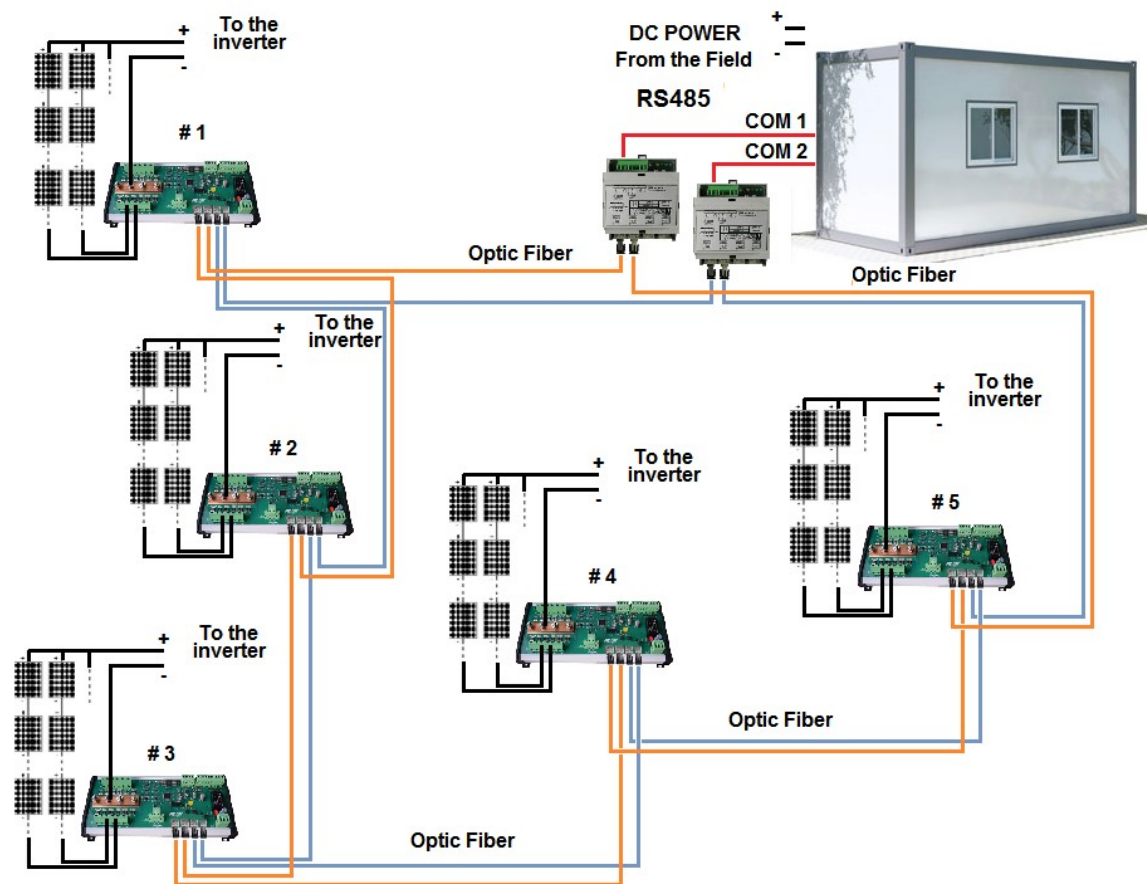

Fig. 8 - Optic Fiber double ring

1.9 Optic Fiber Multidrop Architecture

Another way and more used to guarantee the redundancy is the multidrop architecture. Also this solution require a Data Logger with two independent COM port and two RS485 to fiber converters, SMU must be equipped with two couple of TX and RX drivers. Only one of the COM port has to be used at the same time: In the example shown in the figure below COM 1 is the main COM. The query packet runs in anticlockwise direction and is forwarded from a SMU to the following: from converter to SMU #1, than repeated to SMU #2 and so on. When the query reaches the addressed SMU, this answer sending the packet to the preceding SMU in clockwise direction. If a fault occur for example between number 3 and 4, the number 4 can't be reached so it can't answer. The Data Logger finds the lack of answer and switch to COM2 reaching the SMU number 4 from the opposite direction.

The main advantage of this architecture is to allow the location of the faulty section of cable or SMU and, at the same time to guarantee the continuity of service. This location and search job is on charge of the Data Logger, that must have a proper algorithm to switch between the COM ports and locate the faulty.

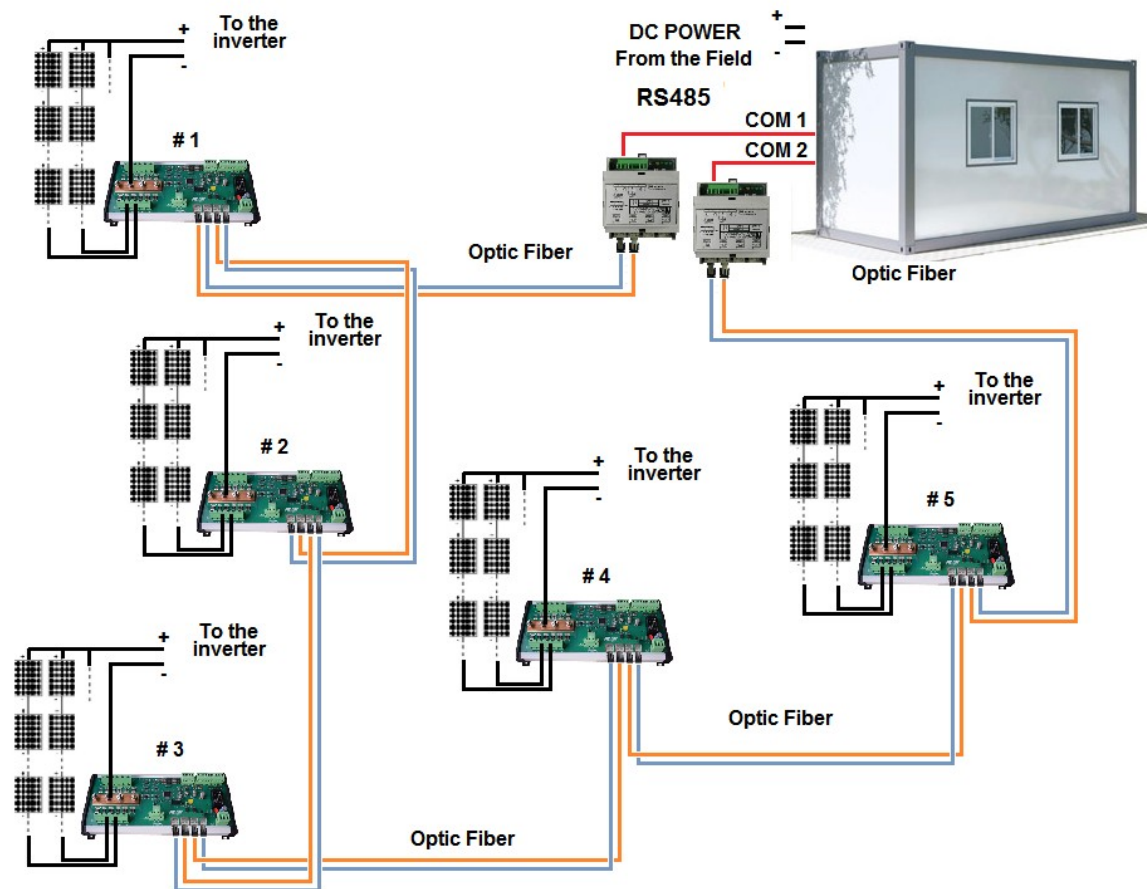

Fig. 9 - Optic Fiber multidrop

2 CONTACTS

GENERAL

Tel: 059 469978
website: www.kernelgroup.it
e-mail: info@kernelgroup.it

COMMERCIAL

Sig.ra Linda Mammi
Tel: 059 469978 Int. 207
e-mail: sales@kernelgroup.it
Skype: mammi.kernel

ADMINISTRATION

Sig.ra Paola Morandi
Tel: 059 469978 Int. 201
e-mail: amministrazione@kernelgroup.it
Skype: morandi.kernel

PURCHASING and PRODUCTION

Sig. Stefano Catuogno
Tel: 059 469978 Int. 204
e-mail: produzione@kernelgroup.it
Skype: catuogno.kernel

TECHNICAL OFFICE

Sig. Alessandro Muratori
Tel: 059 469978 Int. 205
e-mail: alessandro.muratori@kernelgroup.it
Skype: muratori.kernel

Support
Tel: 059 469978 Int. 209
e-mail: support@kernelgroup.it
Skype: support.kernel

Sig. Morisi Luca
e-mail: luca.morisi@kernelgroup.it
Skype: morisi.kernel

Kernel Sistemi s.r.l. , via Vignolese n. 1138
41126 Modena - ITALY
Tel. 059 469 978 - Fax 059 468 874
www.kernelgroup.it